

User Manual

JOFRA STS-102 A 030/035

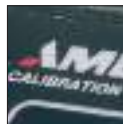

User Manual

JOFRA STS-102 A 030/035

© Copyright 2010 AMETEK Denmark A/S



STS -102 A 030



STS-102 A 035

List of contents

1.0	General information	3
3.0	Introduction	5
4.0	Functionality	6
	4.1 Functional description	6
	4.2 Connections	6
	4.3 Serial number.....	7
5.0	Operation	8
	5.1 Operation area	8
6.0	Maintenance	9
7.0	Technical specifications	10
8.0	Calibration of temperature sensors for sanitary process connection	12
	8.1 Accessories kit for dry calibration	12
	Flange	13
	8.2 The reference sensor	13
	8.3 The calibration sequence.....	15
	8.4 Drilling instructions.....	16

1.0 General information

This manual is only effective for the following product:

- **JOFRA STS-102 A 030**
- **JOFRA STS-102 A 035**

The product is manufactured by:



AMETEK Denmark A/S
Gydevang 32-34
3450 Allerød - Denmark

TEL: +45 48 16 80 00
FAX: +45 48 16 80 80

CE-label



Your new temperature sensor bears the CE label and conforms to the RoHS Directive 2011/65/EU and 2015/863/EU*.

*from serial no. 686126-XX

2.0 Safety instructions



Read this manual carefully before using the sensor!

In order to avoid any personal injuries and/or damage to the sensor all safety instructions and warnings must be observed.



Disposal – WEEE Directive

These calibrators contain Electrical and Electronic circuits and must be recycled or disposed of properly (in accordance with the WEEE Directive 2012/19/EU).



Warning

- Do not use in hazardous area.
- Handle carefully.
- Never exceed temperature range



Caution...

- When measuring temperature in fluids (e.g. at re-calibration) the enclosed protection tube must be used (STS-102 A 030 only).
- The probe must **always** be protected against any mechanical damage.
- The probe must **never** be exposed to mechanical shock effects.
- Avoid thermal shock
- Any bending of the probe may cause permanent damage
- **Never** use power or tools to place the probe.

3.0 Introduction

The JOFRA STS-102 A 030 and JOFRA STS-102 A 035 probes are specially designed for fast and traceable calibration and temperature measuring with your JOFRA equipment and is ready for use.

The JOFRA STS-102 A 030 probe is through its functional design adapted for calibration of short temperature sensors in dry-block calibrators.

The JOFRA STS-102 A 035 probe is through its functional design adapted for calibration of short temperature sensors in both dry-block and liquid bath calibrators.

Please read this manual carefully before use, to obtain maximum value of your calibration system.



Warning

- Do not use in hazardous area.
- Handle carefully.
- Never exceed temperature range

4.0 Functionality

4.1 Functional description

The sensor can be used for measuring temperature in the range:

STS-102 A 030: -50°C to 155°C (-58°F to 311°F).

STS-102 A 035: -50°C to 165°C (-58°F to 329°F).

The sensor is designed for measuring temperature in a dry-block calibrator.



Caution...

When measuring temperature in fluids with STS-102 A 030 (e.g. at re-calibration) the enclosed protection tube must be used.

The STS-102 probes may be supplied with certificates for a limited temperature range.

4.2 Connections

The probe is delivered with a connecting cable and with the following options:

Model with Lemo connection: 1 metre cable

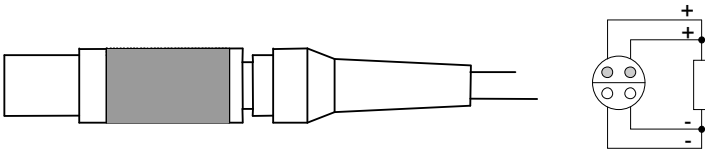

Model with Redel/Lemo connection: 1 metre cable

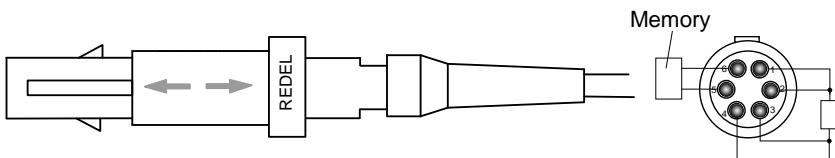

4.3 Serial number

The serial number is placed on the connector as shown on the photo below:



5.0 Operation

5.1 Operation area

All the probes are intended for use in areas, which meet the following operating conditions:

Probe cable	:	-50°C to 165°C (-58°F to 329°F)
Probe connector	:	-20°C to 70°C (-4°F to 158°F)
Storage temperature	:	-20°C to 70°C (-4°F to 158°F)
Humidity	:	0% to 90% RH
Protection class	:	IP 50 (STS-102 A 030) IP 68 (STS-102 A 035)



Warning

- Do not use in hazardous areas.

6.0 Maintenance

The probe does not require specific maintenance before or after use. The user may carry out the following procedure himself:

Cleaning sensor : Use alcohol or water and a soft cloth.



Caution...

- The probe must **always** be protected against any mechanical damage.
- The probe must **never** be exposed to mechanical shock effects.
- Avoid thermal shock
- Any bending of the probe may cause permanent damage

7.0 Technical specifications

STS-102 A 030:

Type	: 4 wire Pt100. $\alpha_{100} = 0.00385 \text{ 1/ } ^\circ\text{C}$
Probe length	: 30 mm / 1.2 inch.
Temperature range	: -50°C to 155°C (-58°F to 311°F)
Hysteresis @0°C / 32°F	: $\pm 0.01^\circ\text{C} / 0.018^\circ\text{F}$
Stability ¹⁾ @0°C / 32°F	: typ. $0.025^\circ\text{C} / 0.045^\circ\text{F}$
Repeatability	: $0.002^\circ\text{C} / 0.0036^\circ\text{F}$
Diameter	: OD4 mm
Immersion depth	: Min. 30 mm / 1.2 inch.
Media compatibility	: AISI 316 TI
Response time	: $\tau_{0.9} = 16 \text{ sec. (measured in water)}$
Self-heating effect	: $0.06^\circ\text{C} / \text{mW} / 0.108^\circ\text{F} / \text{mW}$
Recommended meas. current	: 1 mA
Connections	: 6 pol Redel or 4 pol Lemo plug
Insulation resistance	: 20 Mohm @ 155°C

¹⁾ when exposed to 155°C (311°F) for 200 hours. Stability will depend on actual use of the sensor.

STS-102 A 035:

Type	: 4 wire Pt100. $\alpha_{100} = 0.00385 \text{ 1/ } ^\circ\text{C}$
Probe length	: 35 mm / 1.4 inch.
Temperature range	: -50°C to 165°C (-58°F to 329°F)
Hysteresis @ 0°C / 32°F	: $\pm 0.01^\circ\text{C}$ / 0.018°F
Stability ¹⁾ @ 0°C / 32°F	: typ. 0.025°C / 0.045°F
Repeatability	: 0.002°C / 0.0036°F
Diameter	: OD4 mm
Immersion depth	: Min. 35 mm / 1.4 inch.
Media compatibility	: AISI 316 TI
Response time	: $\tau_{0.9} = 21 \text{ sec.}$ (measured in water)
Self-heating effect	: $0.08^\circ\text{C} / \text{mW}$ / $0.144^\circ\text{F} / \text{mW}$
Recommended meas. current	: 1 mA
Connections	: 6 pol Redel or 4 pol Lemo plug
Insulation resistance	: 20 Mohm @ 165°C

¹⁾ when exposed to 165°C (329°F) for 200 hours. Stability will depend on actual use of the sensor.

Accredited certificate:

If the STS-102 A reference probe is supplied with a certificate, the calibration is carried out as recommended below according to the ITS 90 temperature scale. The probes are as standard calibrated in the range:

STS-102 A 030: -45°C to 155°C (-49°F to 311°F).

STS-102 A 035: -45°C to 165°C (-49°F to 329°F).

It is recommended to calibrate in minimum 3 to 6 calibration points (depending on the temperature range) above 0°C and in minimum 2 calibration points beneath 0°C .

8.0 Calibration of temperature sensors for sanitary process connection

8.1 Accessories kit for dry calibration

This kit can only be used with the ATC-156, A or B version (123859), RTC-156/168 A, B or C version (127279). When used with RTC-168 A, B or C, adaptor 130196 is required.

Instructions for accessories kit for calibration of sanitary sensors:



The accessories kit, Part No. 123859 (ATC) / 127279 (RTC) contains the following parts:

- 1 pcs. carrying case for safe storing of accessories
- 5 pcs. undrilled insertion tubes
- 1 pcs. STS-102 A 030 reference probe with cable. Temperature range -50 to 155 °C
- 1 pcs. accredited certificate
- 1 pcs. user manual
- 1 pcs. protection tube

When calibrating sanitary sensors or sensors with short insertion lengths in general various conditions have to be considered to obtain an optimum and correct calibration. Therefore, AMETEK Denmark A/S recommends that this instruction be followed.

A sanitary sensor is normally similar to one of the two examples shown below.

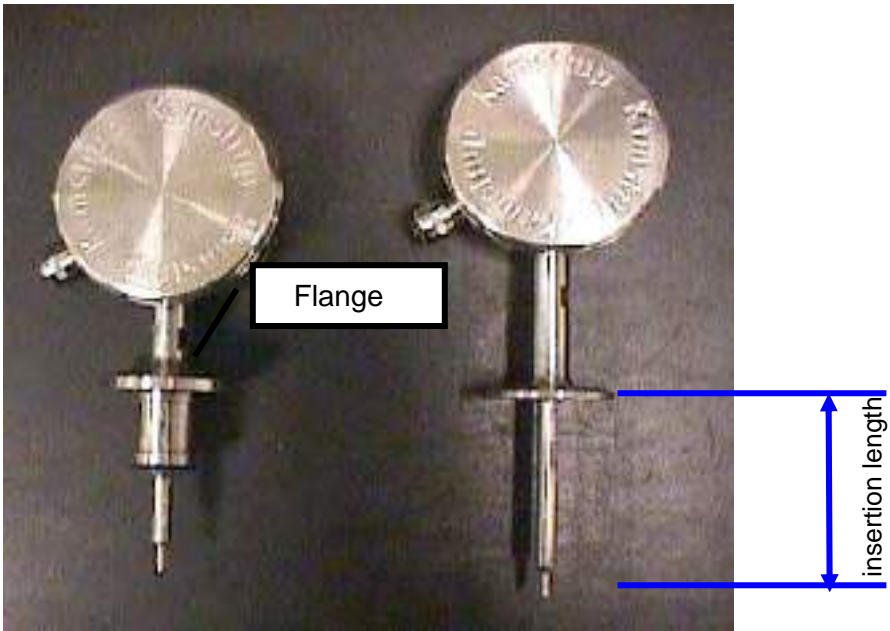

Fig. 1

Due to the very short insertion length, heat transfer through the sensor tube and flange is of great importance to the calibration result. Therefore, it is very important to achieve a good thermal contact to the sensor as well as to the flange.

Make sure that the sensor fits exactly into the supplied insertion tube. It is very important to have good mechanical and thereby also thermal contact between the flange and the horizontal surface of the insertion tube. In other words, there must be no air between the flange and the insertion tube. (See also fig. 2).

8.2 The reference sensor

Included in the package is a STS-102 A 030 reference probe especially developed for the purpose. It is important that this probe is treated careful so it does not suffer any harm. When placing the probe in the reference hole of the insert (\varnothing 4.2 mm) make sure that there is no mechanical resistance.



Caution...

Never use excessive force or tools to place or remove the sensor as this may damage the sensor.

When the calibration is over, the STS-102 A 030 reference probe should be removed from the insert and stored in an appropriate place, for example in the carrying case included in the delivery.



Note...

We recommend recalibrating the STS-102 A 030 reference probe at least once a year, more if there is any doubt about its measuring capability.

The STS-102 A 030 reference probe may be calibrated as an independent unit or as a system together with the calibrator.

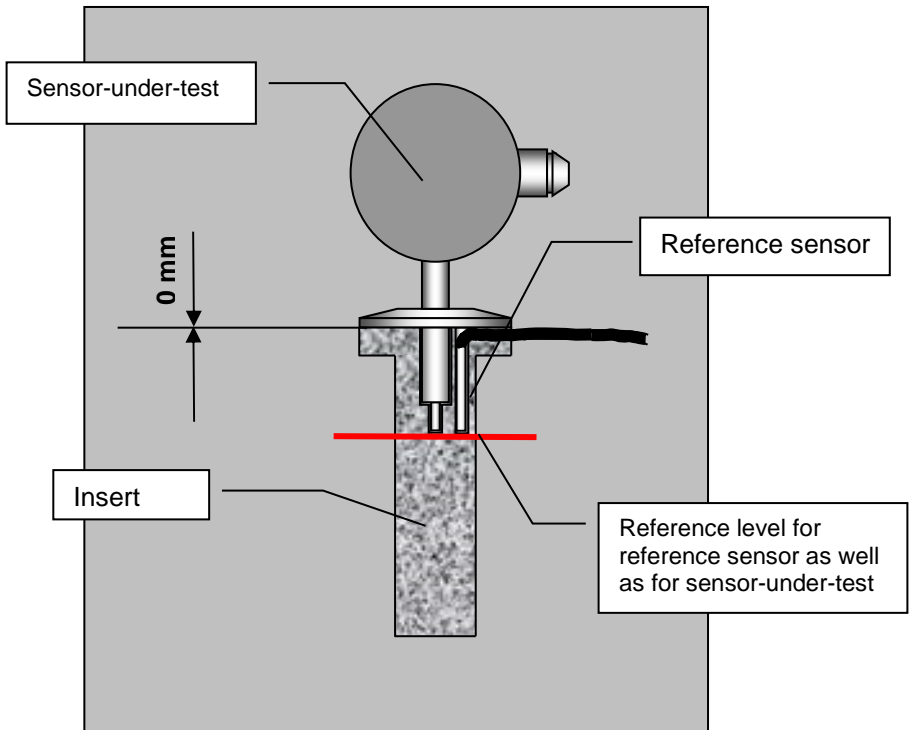

Fig. 2

8.3 The calibration sequence

1. Place the special insert in the calibrator.
2. Place the STS-102 A 030 reference probe in the reference hole of the special insert. Make sure that the STS-102 A 030 reference probe reaches down to the bottom. The cable is placed in the groove of the insert. If the calibrator's reference input is used, make sure that the correct calibration data for the STS-102 A 030 reference probe have been downloaded, see user manual 105447 for ATC-156B or 127139 for RTC-156B and C. If another reference instrument is used, please follow the instructions for this.
3. Place the sanitary sensor in the insert and make sure that the cable of the reference probe is not jammed, but completely free.
4. When calibrating it is a good idea to try to create a calibration situation as close to reality as possible.
5. If the sensor is normally insulated in the process, it should also be insulated in a similar way during the calibration to secure the same thermal conditions. (See fig. 3).

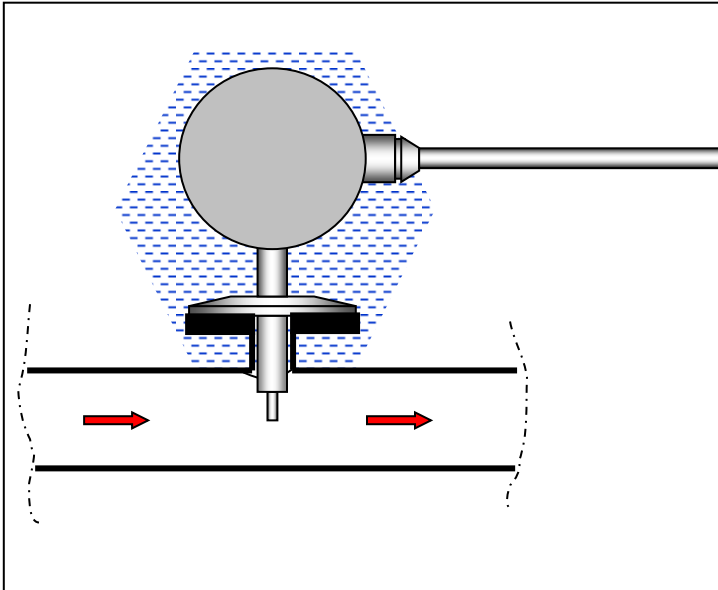

Fig. 3

6. Calibration and setup of the calibrator as usual and as described in the user manual.

Please note that all temperature points and the accuracy during the calibration must relate to the reference probe and not to the “Read” value in the display.

To avoid discrepancies between “Set” value and “Read” and “True” values it is recommended to use the “Set Follows True” function as described in the user manual 105447 for the ATC or 127139 for RTC-156 calibrator. If using this function, calculate on a prolonged calibration time of approx. 10 minutes per calibration point.

8.4 Drilling instructions

In order to obtain good measuring results it is important that the hole of the insert fits exactly into the dimensions of the sensor tube to ensure a good contact between the sensor and the insert. It is especially important that the flange of the sensor fits tight to the surface of the insert.

Procedure:

1. The part of the sensor that must be dropped down into the insert is measured. The diameter “d” and the length “l” must be measured. If the sensor has different diameters, all of these must be measured as well as their corresponding lengths. It is important to note that there where the change in the sensor’s diameter occurs the transition is gradual in an arched form (“r1” and “r2”).
2. The hole for the sensor is placed in the centre of the insert. The diameter is stated as the measured diameter + 0.2 mm. The tolerance of the diameter must be ± 0.05 as indicated in fig. 4.
3. The length of the hole for the sensor is the measured length + 0.5 mm.
4. The hole for the reference probe must be similar to the total length of the sensor “l1”, see fig. 4. The diameter of the hole for the reference probe is $\varnothing 4.2$ mm as indicated in fig. 4.

5. The hole for the reference probe is placed in the drilling. There need to be 3 mm between the diameter of the reference probe and the largest diameter of the sensor-under-test.

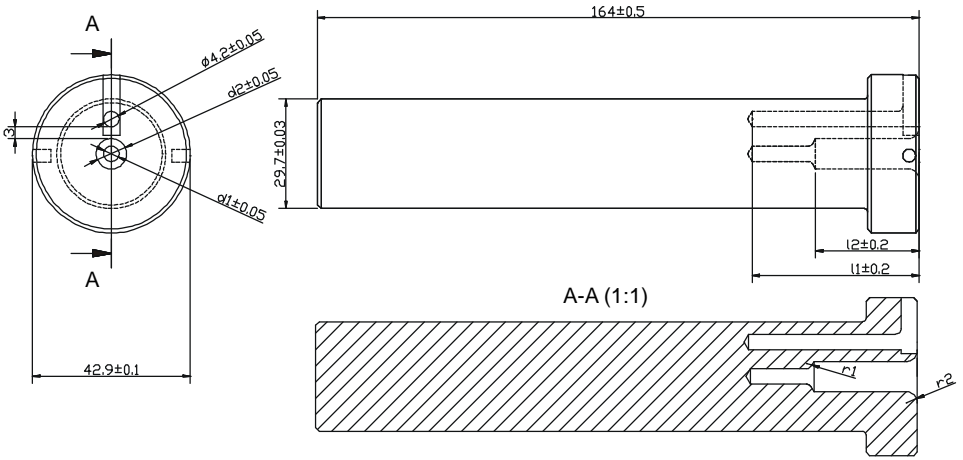

Fig. 4



SENSORS, TEST & CALIBRATION

www.ametekcalibration.com

UK

Tel +44 (0)1243 833 302
stc.uk@ametek.com

USA - California

Tel +1 (800) 444 1850
crystal@ametek.com

India

Tel +91 22 6196 8200
jofra@ametek.com

France

Tel +33 (0)1 30 68 89 40
general.lloyd-instruments@
ametek.fr

USA - Florida

Tel +1 (800) 527 9999
cal.info@ametek.com

Singapore

Tel +65 6484 2388
jofra@ametek.com

Germany

Tel +49 (0)2159 9136 510
info.mct-de@ametek.de

China - Beijing

Tel +86 10 8526 2111 ext. 19
stc.china@ametek.com

Denmark

Tel +45 4816 8000
jofra@ametek.com