

# GaugeCalHP

---

## Rebuild Kit Instructions



## ■ Required Tools

### ▶ Allen Keys

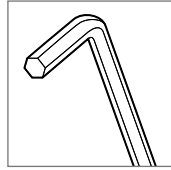

5/64"  
3/32"  
3/16"  
1/4"  
9/16"

### ▶ Phillips-head Screwdriver

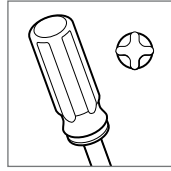

### ▶ Drill Rod (or similar tool)

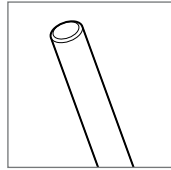

Ø=0.128"-0.135"

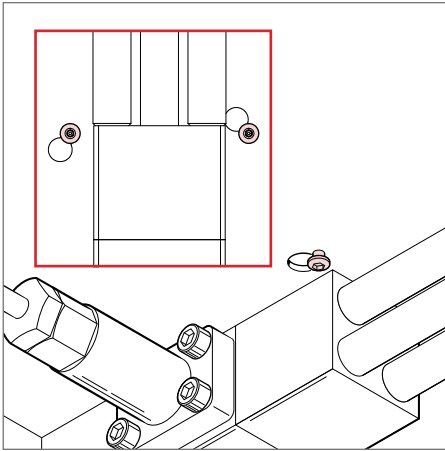

## ■ Main Components and Assemblies

- 1 Remove all gauges from the comparator.
- 2 From the underside of the comparator, use a 5/64" Allen key to loosen the two Set Screws securing the Reservoir Assembly to the Shroud.

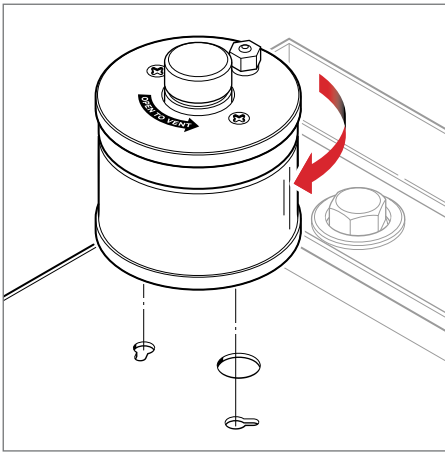

- 3 From the topside of the comparator, twist the Reservoir Assembly clockwise, and then lift to remove it from the Shroud.

► Rebuild the Reservoir Assembly using the [procedure on page 7](#).

- 4 Position the GaugeCalHP vertical (Handle end up) then turn the Handle clockwise to drive any remaining fluid from the system.

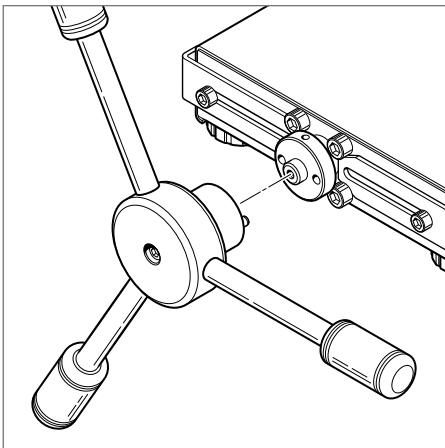

- 5 Using a 3/16" Allen key, loosen the center Captive Screw and remove the Handle Assembly.

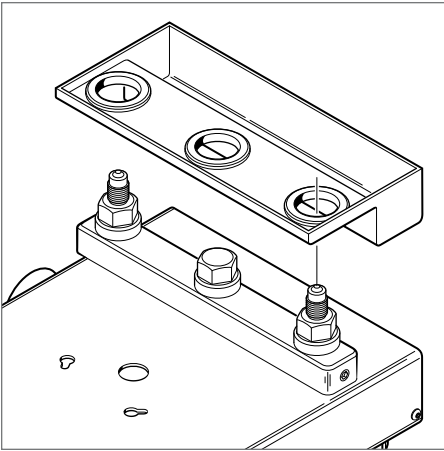

- 6** Lift the Drip Tray to remove it from the Manifold Assembly.

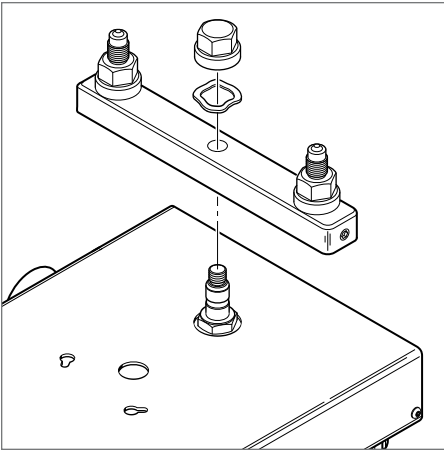

- 7** Remove the Manifold Nut and Wave Spring from the Manifold Fitting.

- 8** Lift the Manifold Assembly to remove it from the Manifold Fitting.

- ▶ Rebuild the Manifold Assembly using the [procedure on page 5](#).

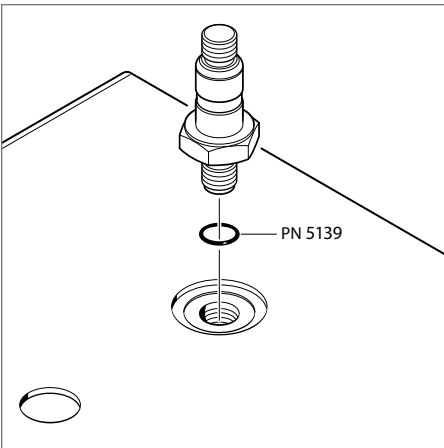

- 9** Remove the Manifold Fitting from the Manifold Base.

- 10** Replace the O-ring (PN 5139).

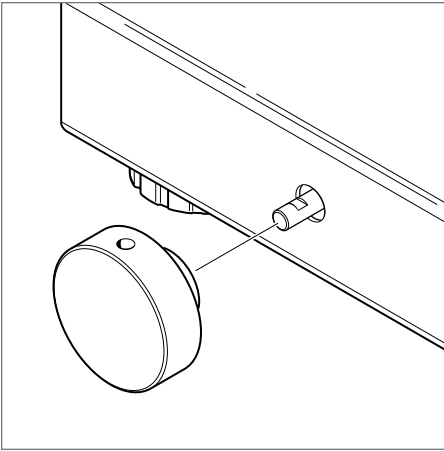

- 11** Using a 5/64" Allen key, loosen the Set Screw and remove the Fine Adjust Knob.

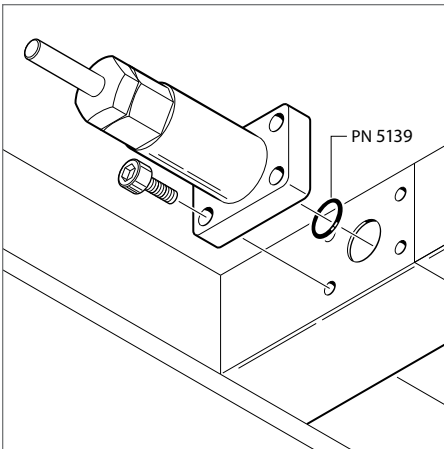

- 12** From the underside of the comparator, use a 9/16" Allen key to remove the four Socket Head Screws securing the Fine Adjust Assembly to the Manifold Base.

- 13** Remove the Fine Adjust Assembly and replace the O-ring (PN 5139).

- Rebuild the Fine Adjust Assembly using the [procedure on page 6](#).

**When re-installing the Fine Adjust Assembly, the Socket Head Screws should be torqued to a value of 18–20 in-lbs.**

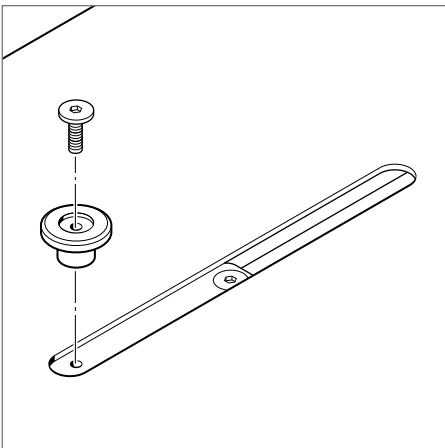

- 14** Using a 5/64" Allen key, remove the Travel Indicator.

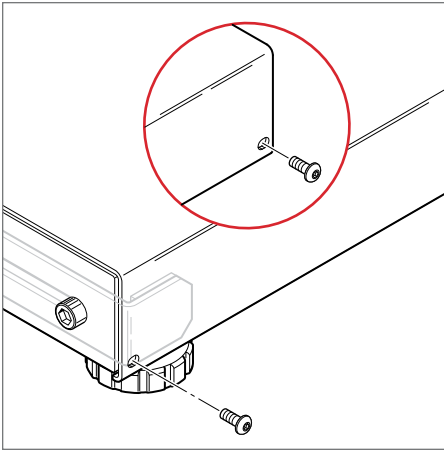

**15** Using a 5/64" Allen key, remove the four Screws from the two sides of the comparator Shroud.

**16** Slide the Shroud to the rear of the comparator to remove it.

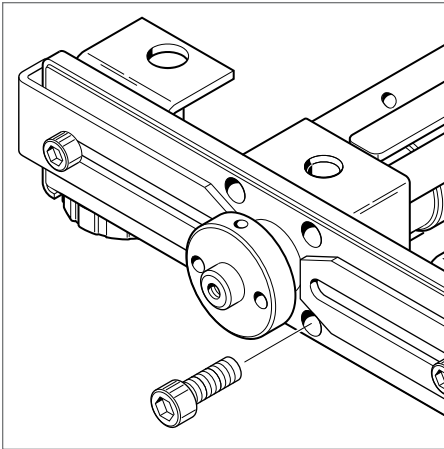

For steps 14-18, it is recommended that the rear assemblies be secured in a vise (or similar fashion) as some force may be required to remove the Piston Assembly and Struts.

**17** Using a 1/4" Allen key, remove the four Socket Head Screws near the Handle Hub.

**18** Slide the Piston Assembly forward, away from the four Struts.

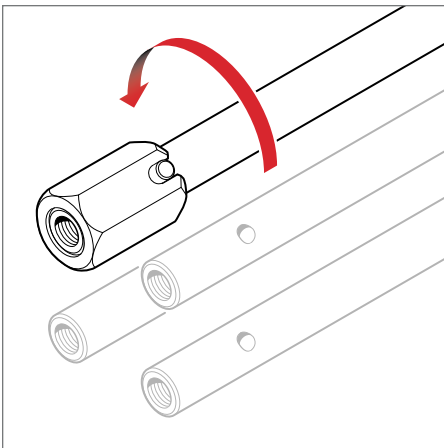

**19** Install the provided Strut Torque Tool and Dowel Pin onto the first Strut.

**20** Remove the Strut by rotating it counter clockwise.

**21** Repeat steps 17 and 18 to remove the other three Struts.

**When re-installing the four struts, they should be torqued to a value of 300 in-lbs.**

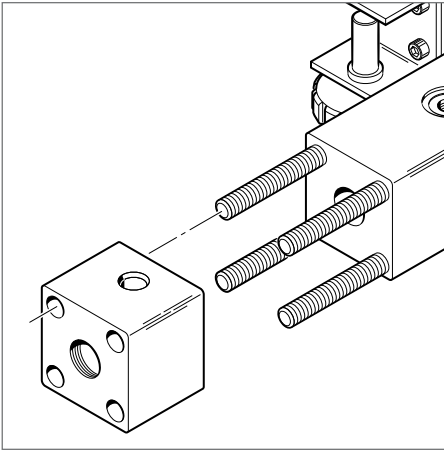

**22** Remove the Gland Assembly from the four threaded Studs.

► Rebuild the Gland Assembly using the [procedure on page 8](#).

**23** Once the required maintenance has been performed on all assemblies, reassemble the comparator by following steps 1-22 in reverse order.

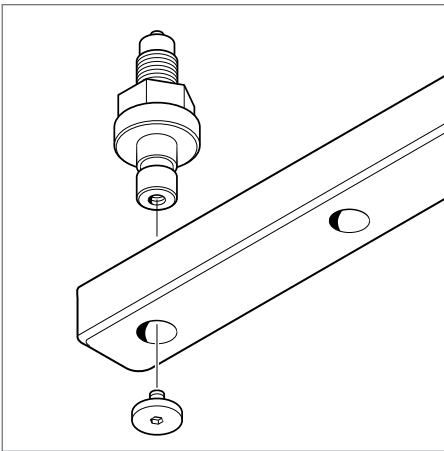

## ■ Manifold Assembly

**1** From the underside of the Manifold, use a 3/32" Allen key to remove the Retainers securing the two outside Fittings.

**2** From the topside of the Manifold, remove the two outside Fittings.

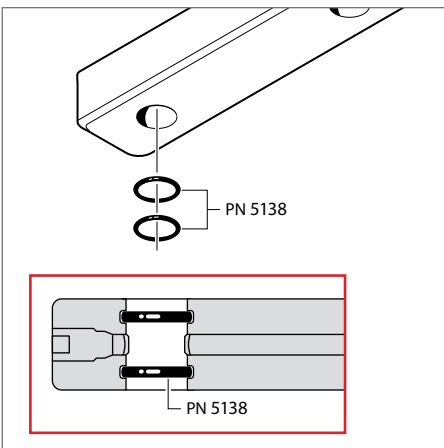

**3** Remove the six O-rings (PN 5138) in the Manifold—two O-rings from each of the three Manifold fitting ports.

**4** Rebuild the Manifold Assembly by following the preceding steps in reverse order, and replacing the six O-rings (PN 5138).

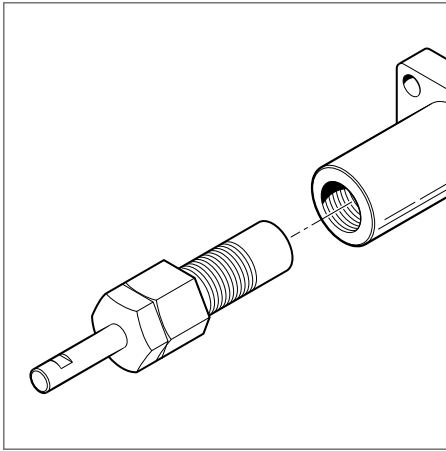

## ■ Fine Adjust Assembly

- 1 Remove the Piston and Retainer Subassembly from the Cylinder.

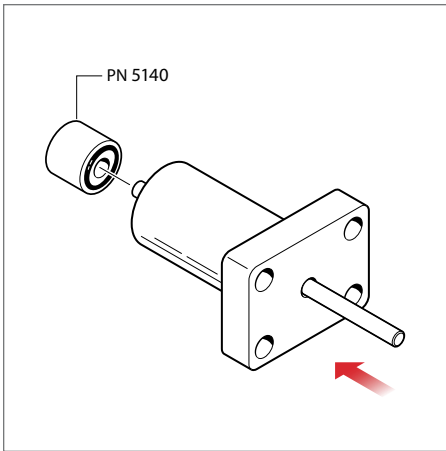

- 2 Using a drill rod or other appropriate tool, push the seal (PN 5140) out through the top of the cylinder.

The tool should have an outside diameter of 0.128"–0.135".

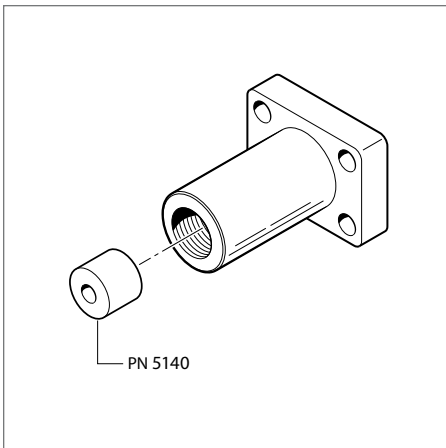

- 3 Carefully and slowly, work the new Seal (PN 5140) down the threads of the Cylinder.

- 4 Once the Seal clears the threads, push it all the way to the bottom of the Cylinder using a Pin or other appropriate tool.

- 5 Complete the Fine Adjust Assembly by threading the Piston and Retainer Subassembly back onto the Cylinder.



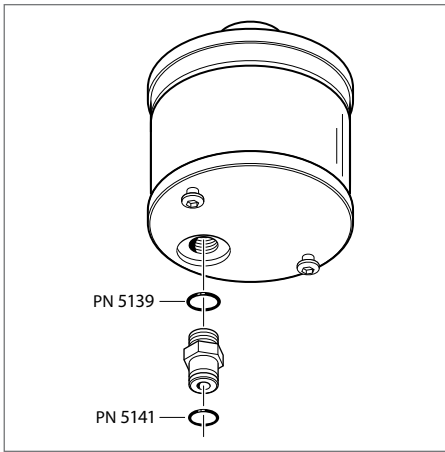

## ■ Reservoir Assembly

- 1** From the underside of the Reservoir, remove the Fitting from the Reservoir Base.
- 2** Remove the Reservoir Fitting and replace the two O-rings (PN 5139) and (PN 5141).

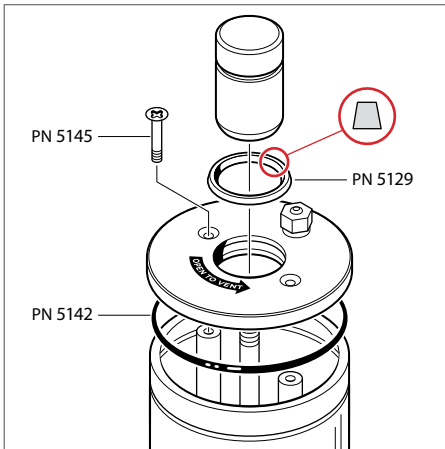

- 3** From the topside of the Reservoir, remove the Reservoir Knob.
- 4** Using a Phillips-head screwdriver, remove the two Reservoir Cap Sealing Screws (PN 5145), and then remove the Reservoir Cap.
- 5** Remove the Reservoir Knob Seal (PN 5129) and the large O-ring (PN 5142) from the Reservoir Cap.

Note that the wider surface of the Reservoir Knob Seal is facing down.

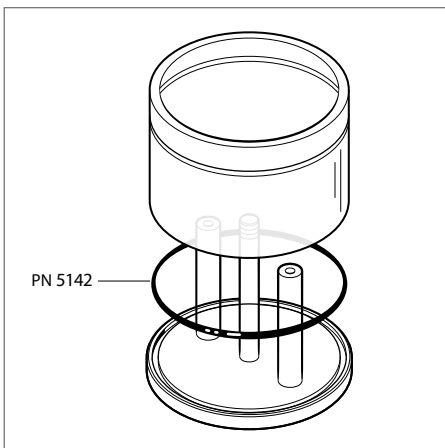

- 6** Remove the Reservoir Tube from the Reservoir Base.
- 7** Remove the large O-ring (PN 5142) from the Reservoir Base.
- 8** Rebuild the Reservoir Assembly by following the preceding steps in reverse order.

Note that the reservoir tube should be oriented so that the etched fill line is near the top.

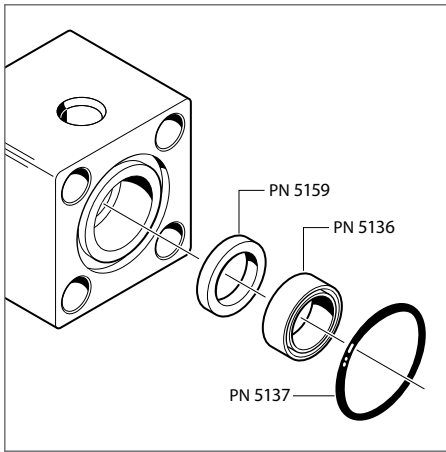

Rear Gland Housing

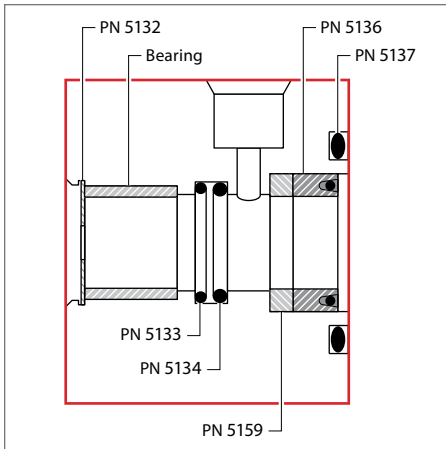

Gland Assembly Cross Section

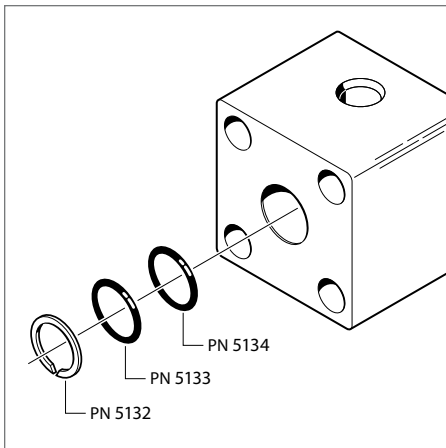

Front Gland Housing

## ■ Gland Assembly

- 1 From the rear of the Gland Housing, remove the O-ring (PN 5137), Gland Seal (PN 5136), and Main Seal Backup Ring (PN 5159).
- 2 From the front of the Gland Housing, inspect the inside diameter of the Bearing to confirm that it is still within specification: 0.501-0.505" (12.7-12.8 mm)
- 3 If necessary, remove the Bearing Retaining Ring (PN 5132) from the front of the Gland Housing.
- 4 Use an appropriate tool to reach through the the Bearing to remove the Backup O-Ring (PN 5133) and Inner O-ring (PN 5134).
- 5 Rebuild the Gland Assembly by installing the Inner O-ring (PN 5134), and Backup O-ring (PN 5133) through the inside of the bearing in the front of the Gland Housing. Then install the Bearing Retaining Ring (PN 5132)
- 6 Through the back of the Gland Housing, install the Main Seal Backup Ring (PN 5159), Gland Seal (PN 5136), and O-ring (PN 5137).

# GaugeCalHP Rebuild Kit Parts List

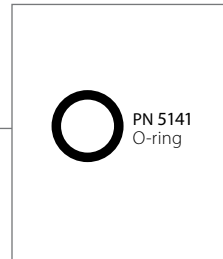
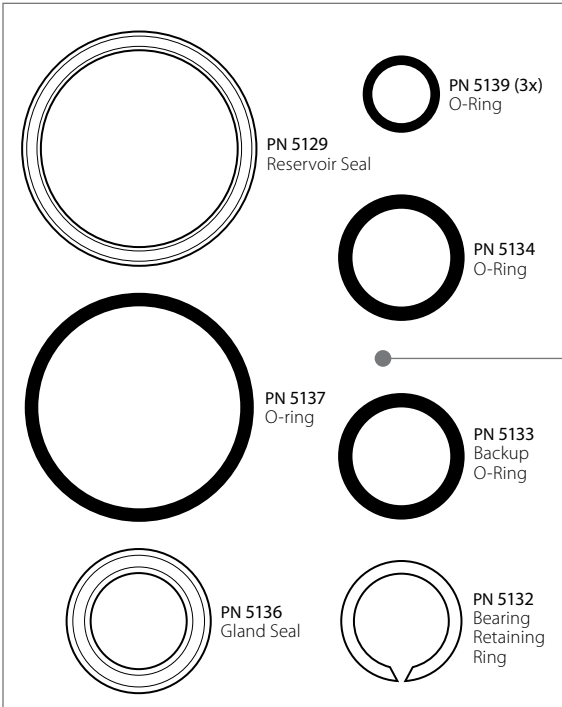
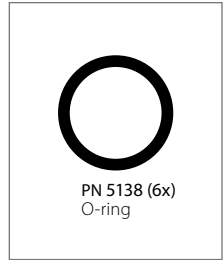
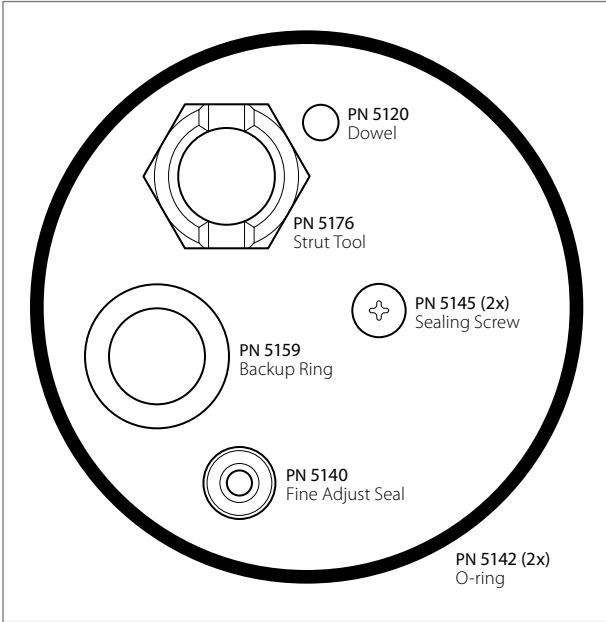



© 2016 Crystal Engineering Corporation

708 Fiero Lane, Suite 9, San Luis Obispo, California 93401-8701

---

